

Coupled THMC Processes under High Temperature in bentonite buffer: Laboratory Experiments, Field Tests, and Modeling

U.S. Nuclear Waste Technical Review Board
Fact Finding Meeting
July 19, 2022

LianGe Zheng, Chun Chang, Sangcheol Yoon, Sharon Borglin, Chunwei Chou, Jonny Rutqvist, Timothy Kneafsey, Yuxin Wu, Seiji Nakagawa, Luca Peruzzo, Jens Birkholzer

Lawrence Berkeley National Laboratory

Funded by the Spent Fuel and Waste Science and Technology, Office of Nuclear Energy, of the U.S. Department of Energy.

Processes Involved in Bentonite Evolution (1)

To ensure favorable features of the bentonite in the long term, understanding and modeling of early-time thermal, hydrological, mechanical and chemical (THMC) perturbations is critical:

- **Thermal process:** Heat emission from waste and transport through bentonite buffer
- **Hydrological process:** Partially saturated bentonite becomes fully saturated after transient de-saturation and re-saturation
- **Mechanical process:** Stress evolution, possibly leading to damage
- **Chemical process:** solute transport, radionuclide migration and mineralogical change

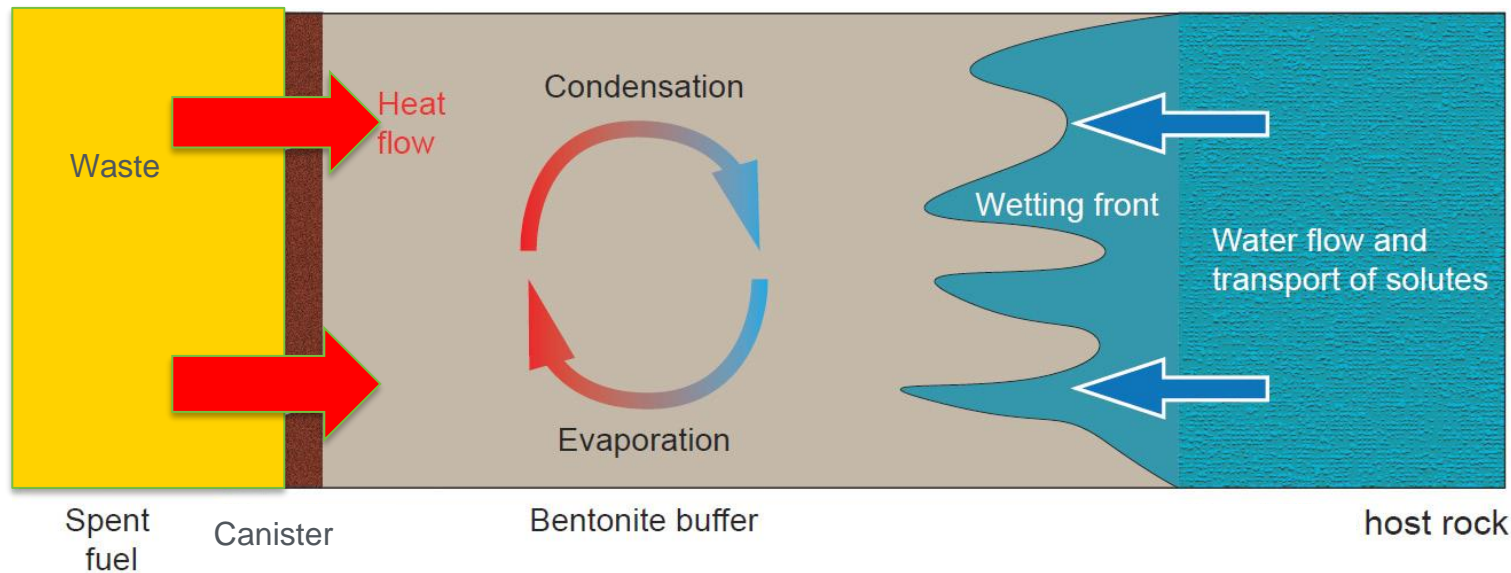

(Modified from Leupin et al, 2014)

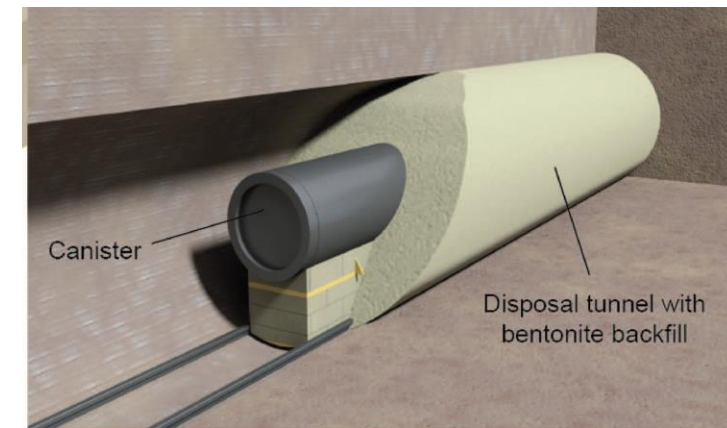

Processes Involved in Bentonite Evolution (2)

THMC processes are coupled and evolve temporally and spatially

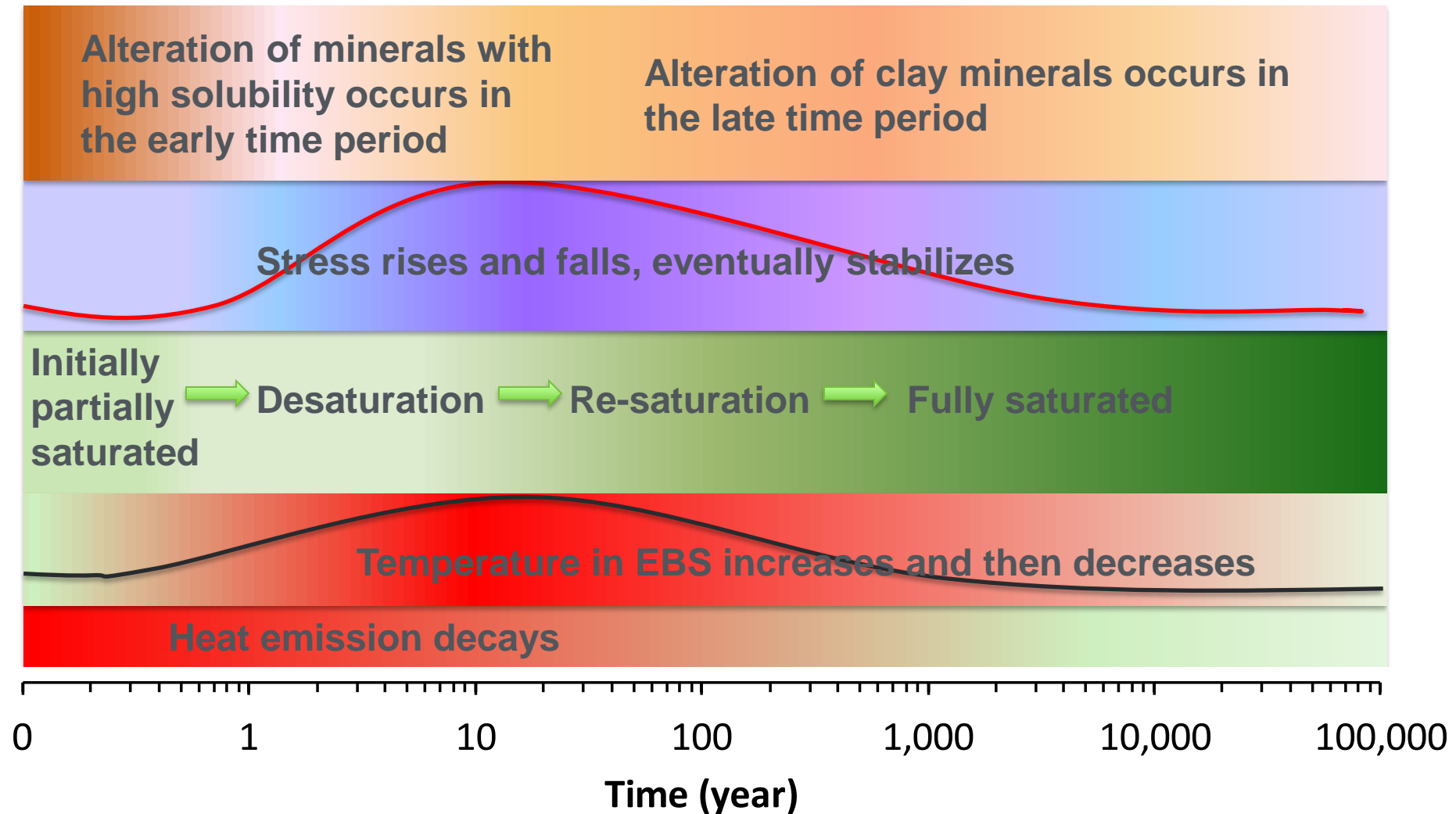

To build a reliable process model, we need to know—

Processes model is the foundation of performance assessment model. To build such models, we need to know:

- **What are the key processes that have to be included in the model?**
- **Do we have reliable constitutive relationships and parameters to describe THM processes?**
 - Porosity and permeability changes
 - Stress evolution
- **Do we have reliable chemical models and parameters to describe chemical processes?**
 - Evolution of pore-water geochemistry in bentonite
 - Mineralogical changes in bentonite
 - Retardation capability
 - Interactions between canister/bentonite/host rock

Studies had focused on the THMC process under 100 °C

What If the Temperature is Higher (200 °C)?

Benefit

- Support Dual Purpose Canister disposal as it can lead to higher temperatures in the engineered and near-field natural barrier system
- Open the possibility of raising thermal limit of 100 °C for small PWR canisters
- Expanding the knowledge and data base to build the confidence

Key knowledge gaps to be narrowed

- When bentonite evolves from partial saturation to full saturation at temperatures up to 200 °C, how does bentonite change hydrologically and mechanically (e.g., boiling temperatures, high pore pressure, high stress, gas transport, etc.)?
- What are the mineralogical alterations of bentonite in the short-term and long-term (e.g., illitization and loss of swelling capacity)?
- Are the models (including processes, constitutive relationships and parameters) developed for 100 °C suitable for high temperature conditions?

Using generic models, laboratory experiments and field tests to address these questions

Experience Gained from Low Temperature THMC Test and Model (1)

An *in situ* test

The full-scale *in situ* test is located in Grimsel, Switzerland, heating started in 1997 at 100 °C, as part of FEBEX (Full-scale Engineered Barrier Experiment) (ENRESA, 2000).

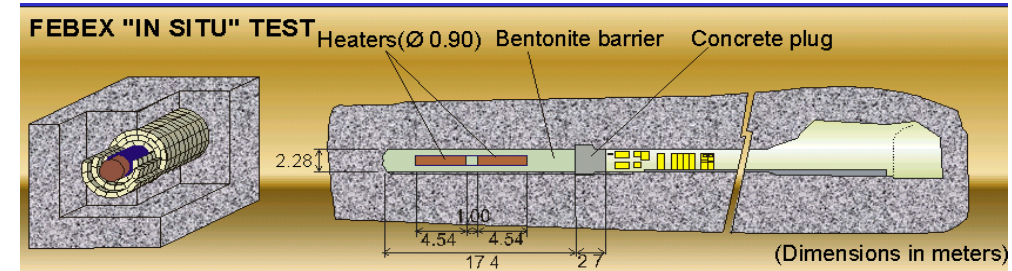

In 2015, Dismantling of Heater #2

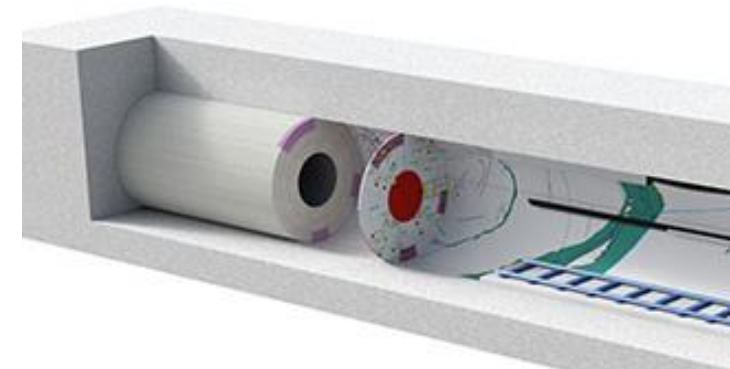

In 2002, Dismantling of Heater #1

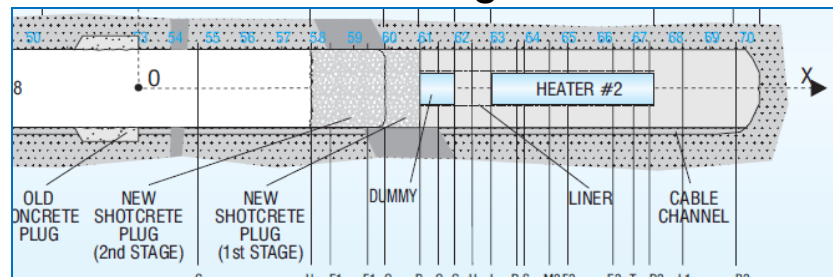

Extensive laboratory tests were carried out to characterize THMC properties of bentonite, concrete, steel liner and granite.

Experience Gained from Low Temperature THMC Test and Model (2)

THMC modeling

Developing the model

- **Thermal model:** Heat convection and conduction
- **Flow model:** Two-phase (gas and water) flow
- **Mechanical model:** Poro-elastic using state surface approach
- **Chemical model:** Aqueous complexation, surface complexation, cation exchange and minerals dissolution/precipitation

Testing the model with THMC data

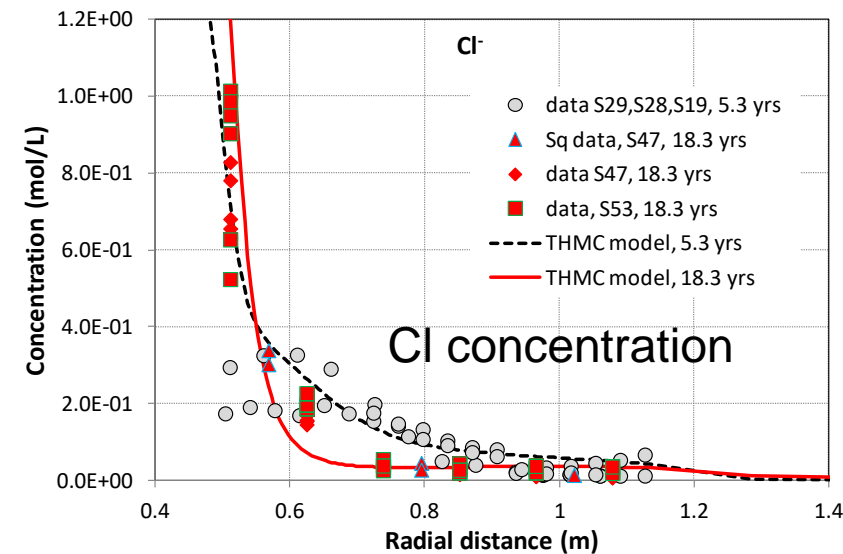
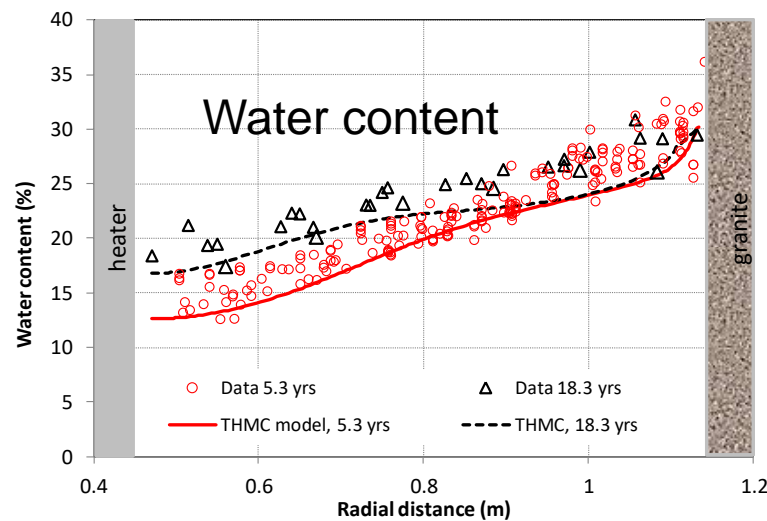

Zheng et al. 2019

Experience Gained from Low Temperature THMC Test and Model (3)

Understanding deepened and modeling capabilities improved

- **Processes needed for modeling bentonite THM evolution:**
 - Thermal conduction and convection
 - Multiphase flow
 - Poro-elasticity
 - Porosity and permeability changes due to swelling
- **About geochemical evolution:**
 - Ion concentrations in pore water are high near the heater, which were largely shaped by transport processes, but also affected by minerals and cation exchange
 - Alterations to carbonate minerals and gypsum happened in the entire bentonite barrier
 - Alterations to clay minerals were moderate and mostly occurred near the heater, which cannot be verified by the data that have large measurement uncertainties
- **Key to increase the robustness of our predictive models for bentonite:**
 - long-term measurements
 - Multiple types of data

Exploration with Generic Models for High T (100 °C vs 200 °C)

Model development

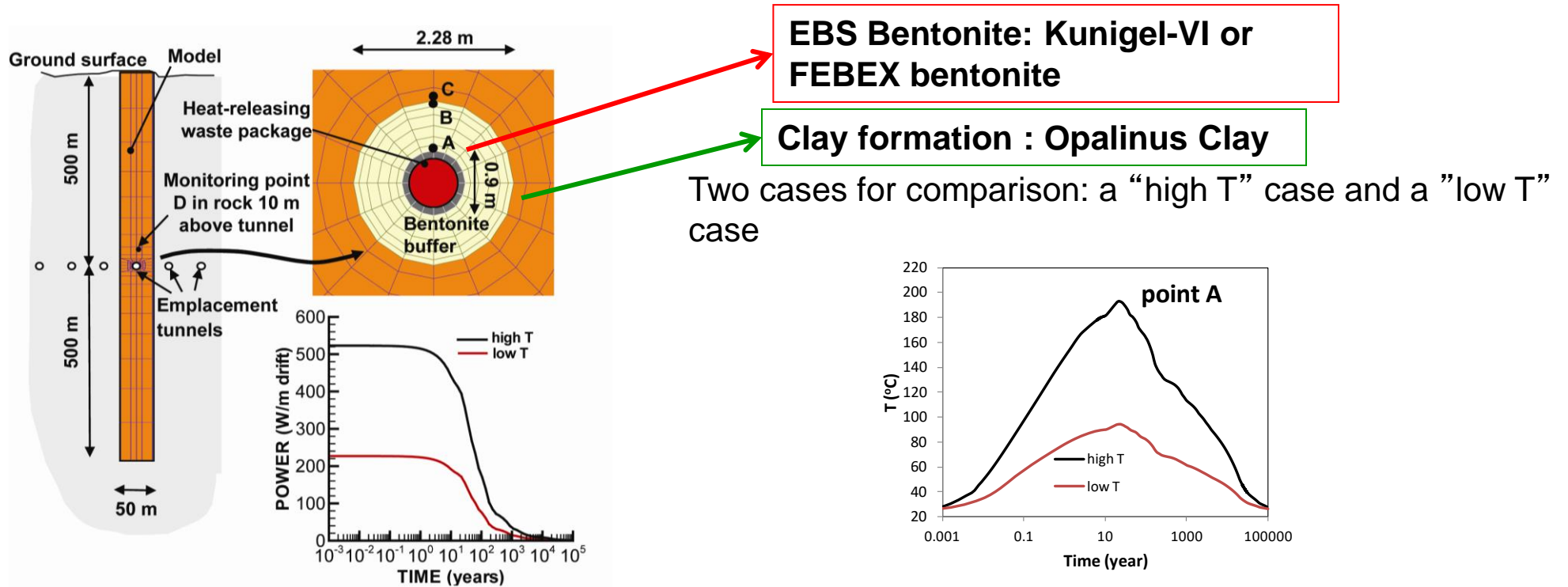

- Chemical model: aqueous complexation, minerals dissolution/precipitation and cation exchangeable
- Illitization was modeled as smectite dissolution and precipitation of illite:

$$\text{Smectite} + 0.52\text{H}^+ + 0.63\text{AlO}_2^- + 0.6\text{K} = \text{illite} + 0.26\text{H}_2\text{O} + 0.08\text{Mg}^{+2} + 0.33\text{Na}^+ + 0.5\text{SiO}_2(\text{aq})$$
- The reaction rate was calibrated against data from Kinnekulle bentonite, Sweden (*Push and Madsen, 1995*)
- Mechanical-chemical coupling was formulated via an extended linear swelling model or Dual structural Expansive Clay Model (BExM)

(Zheng et al., 2015; 2017)

Exploration with Generic Models for High T (100 °C vs 200 °C)

Key finding (1): illitization occurs, temperature plays a key role and bentonite-host rock interaction is important

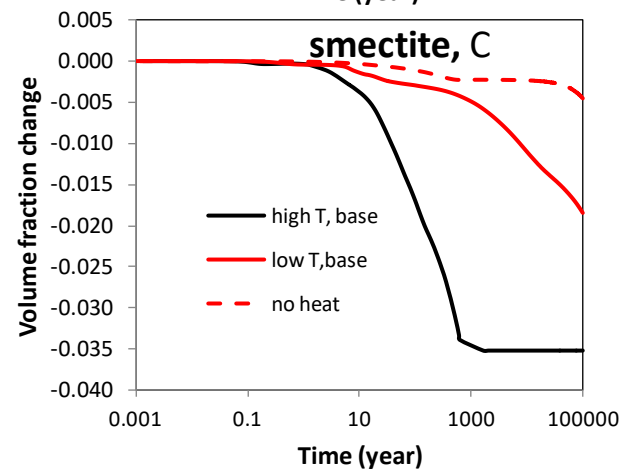
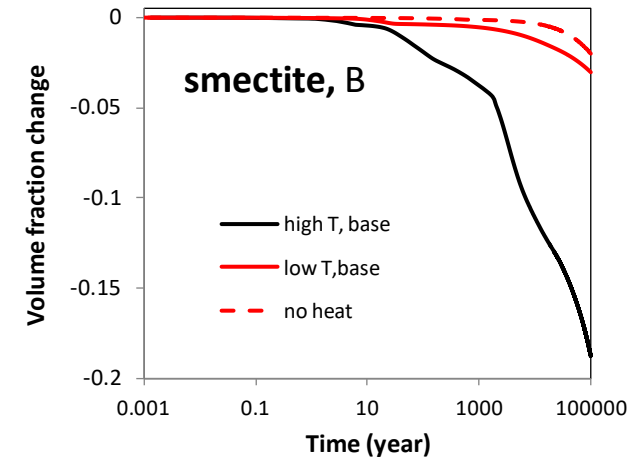
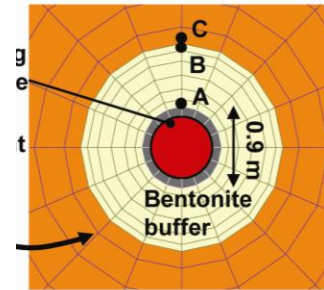
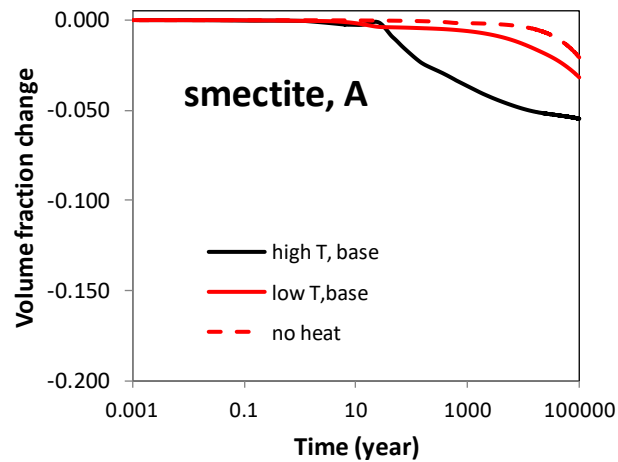

The temporal evolution of smectite volume fraction at points A, B, C, and D for Kunigel-VI bentonite.

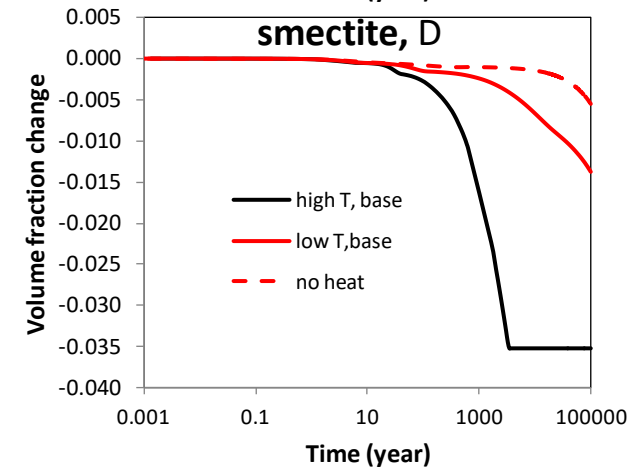

At early times, dissolution of k-feldspar supplies K for illitization; after about 3000 years, illitization in host rock stops and K is transported into bentonite which leads to very different illitization at points A and B

Exploration with Generic Models for High T (100 °C vs 200 °C)

Key finding (2): Swelling stress decreases as a result of chemical changes and such decrease varies case by case

The geochemically induced swelling stress for Kunigel and FEBEX bentonite at points A and B for a “high T” scenario

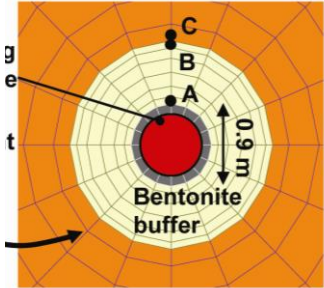

	Kunigel-VI bentonite				FEBEX bentonite			
	Stress reduction by ion concentration		Stress reduction by smectite dissolution		Stress reduction by ion concentration		Stress reduction by smectite dissolution	
	MPa	%	MPa	%	MPa	%	MPa	%
Point A	0.07	7%	0.09	9%	0.006	0.1%	0.17	3.4%
Point B	0.08	8%	0.45	45%	0.06	1.1%	0.6	12%

Laboratory Tests and Modeling (1)

High Temperature Column Experiment on Bentonite

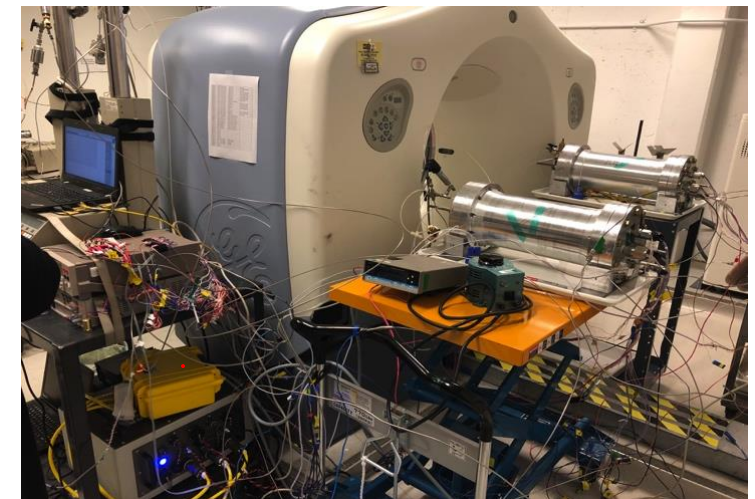
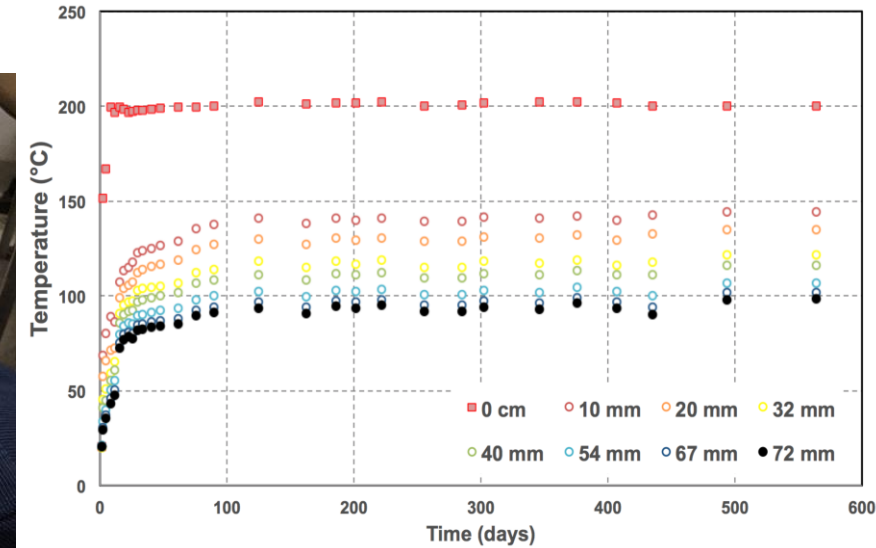
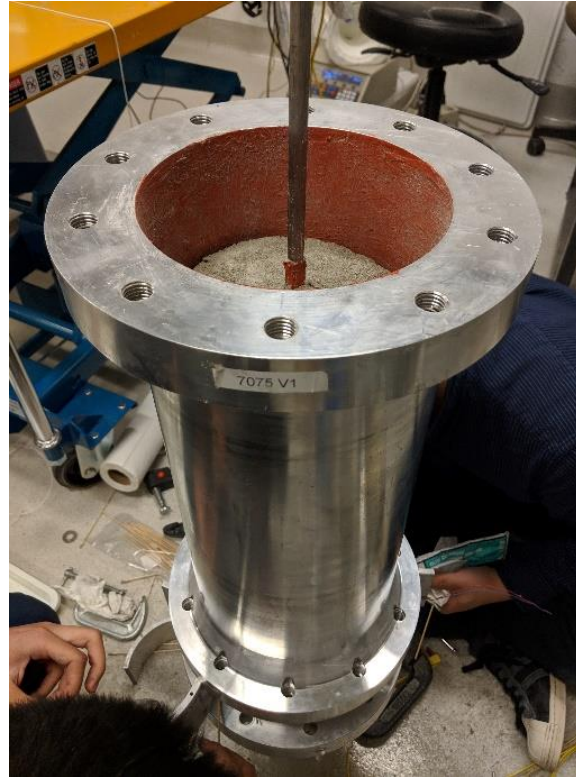
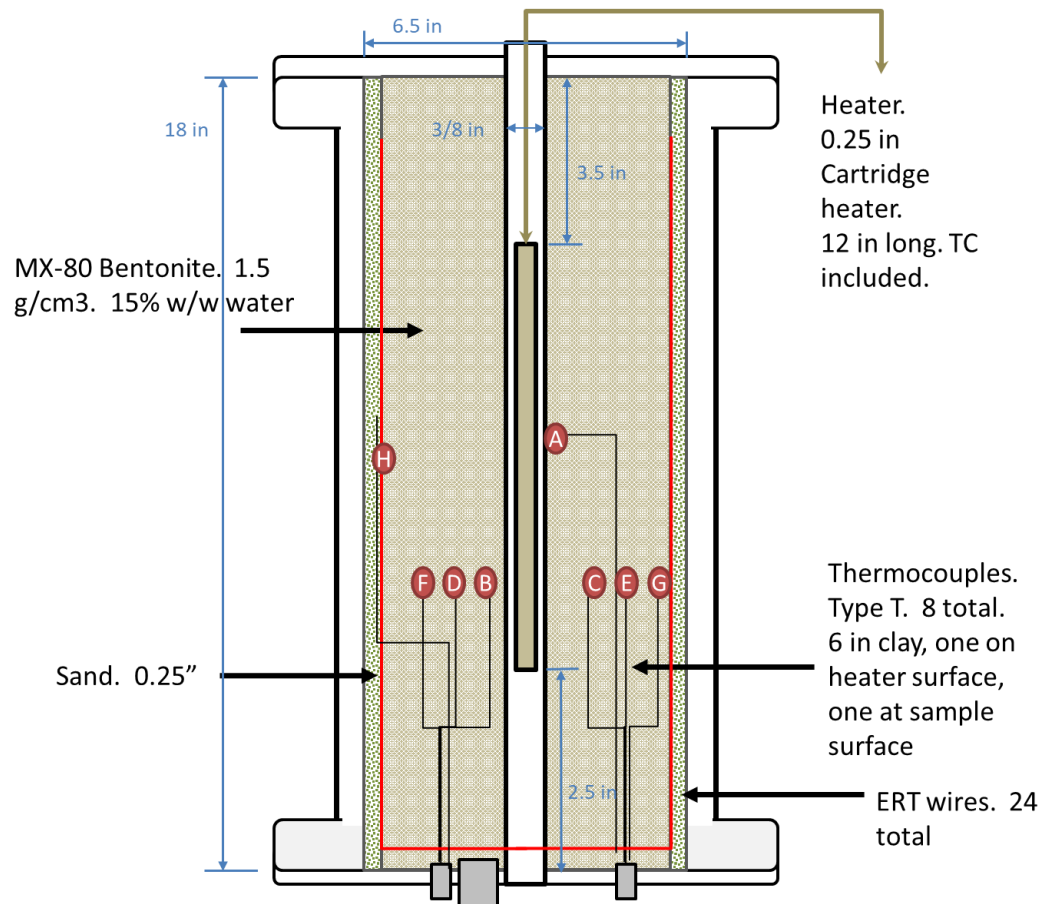

Average for inlet and outlet pressure has been 120 psi (8.3 bars). Flow is 0.11 mL/min. After the bentonite was flooded for 1 day, heater was turned on at 150 °C. After a week the temperature at the heater was maintained at 200 °C

Laboratory Tests and Modeling (2)

High Temperature Column Experiment on Bentonite: Hydration showed by CT scan

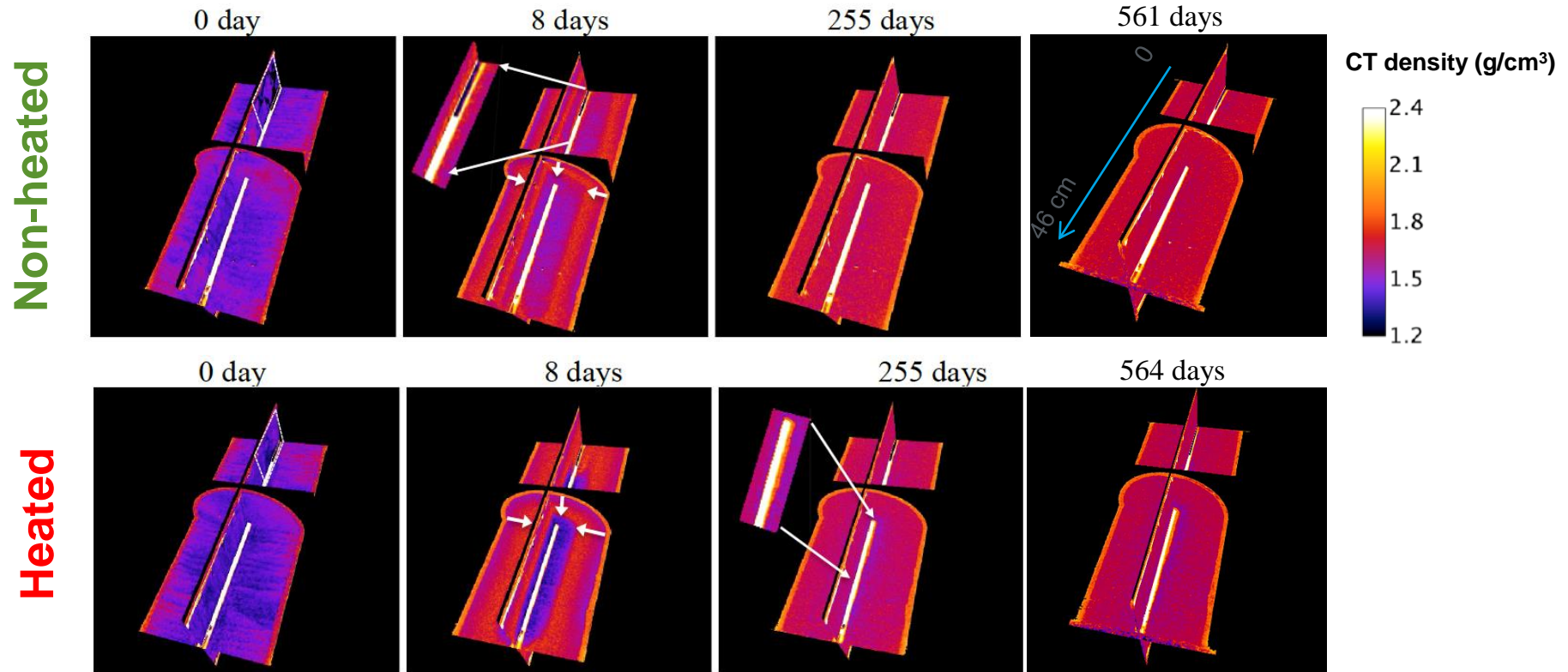

Laboratory Tests and Modeling (3)

High Temperature Column Experiment on Bentonite: Hydration showed by CT scan

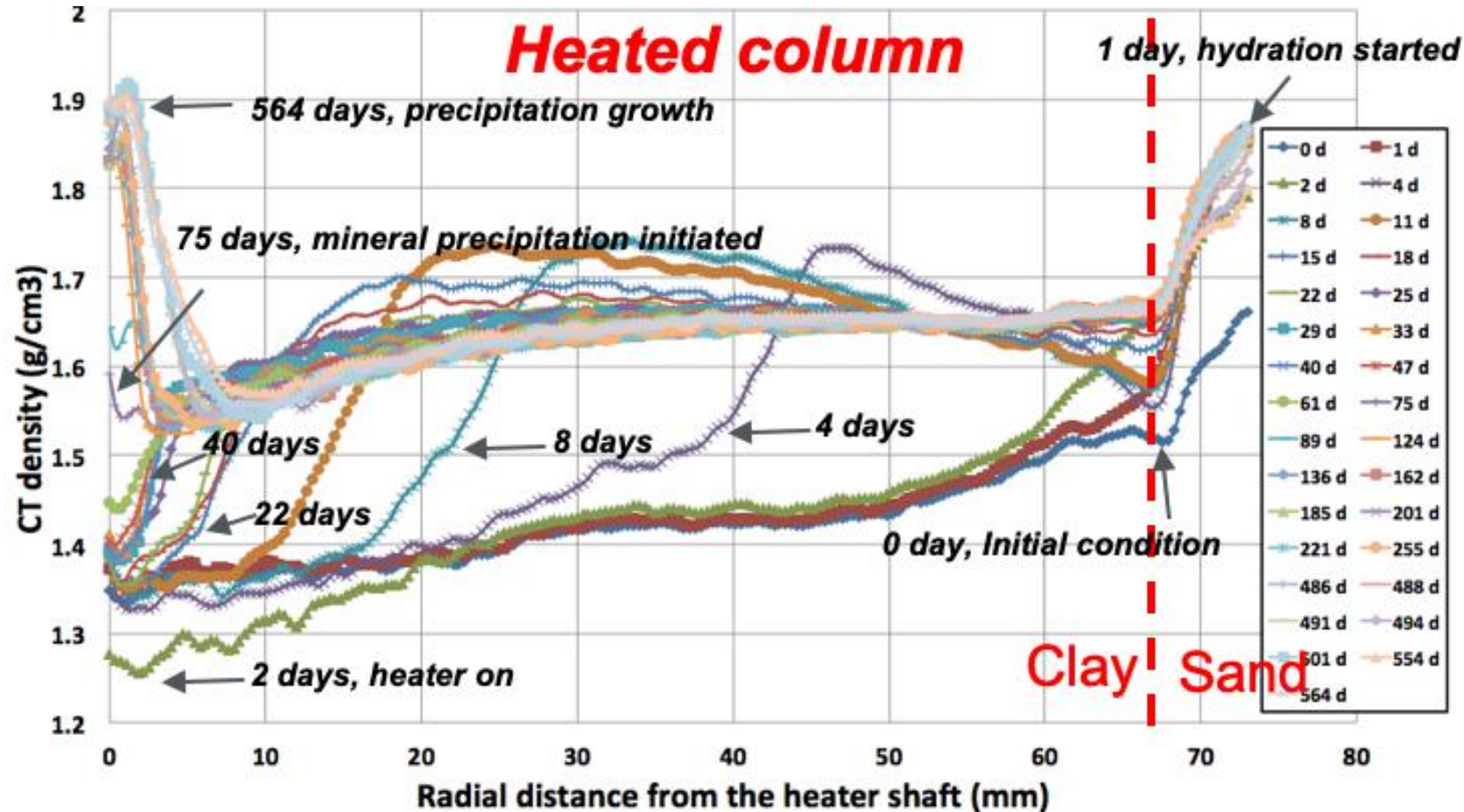

- The column tests and CT images show coupled processes of:
 - (1) Hydration;
 - (2) Clay swelling;
 - (3) Heating dehydration;
 - (4) Swelling- and heating-induced large deformation/displacement;
 - (5) Mineral precipitation.
- These processes occur spatially and time dependent.

Laboratory Tests and Modeling (4)

High Temperature Column Experiment on Bentonite: Displacement

Non-heated

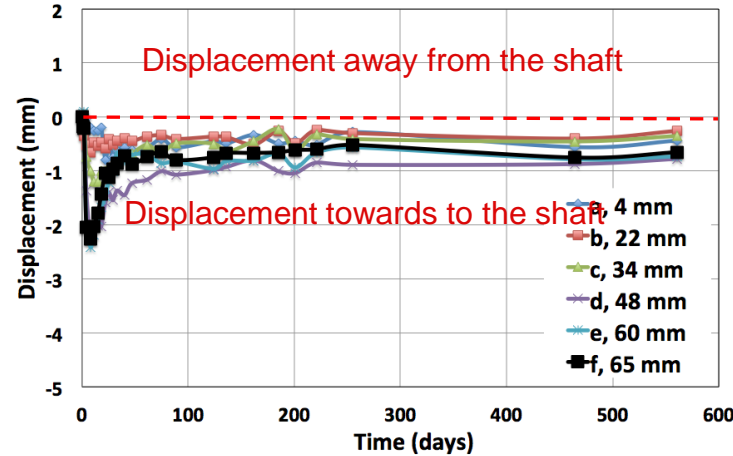
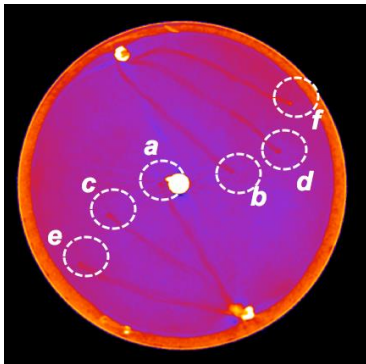

Heated

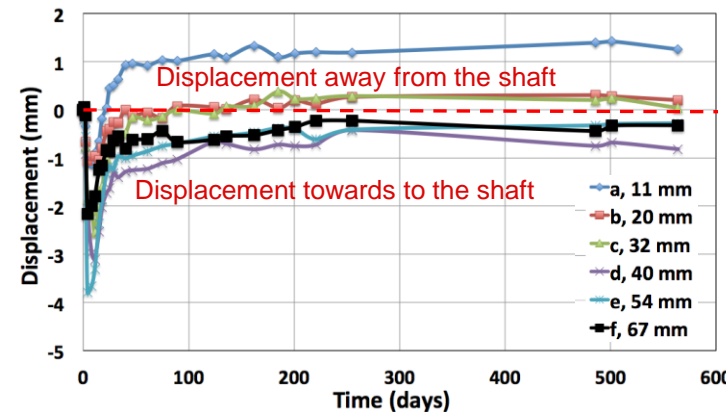
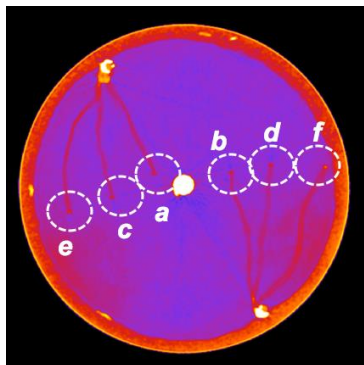

- In both columns, most clay was compacted at early time, then moved back as hydration propagated to the center.
- Heating induced
 - (1) larger compaction at early time, and
 - (2) larger and sustained swelling near the heater shaft.

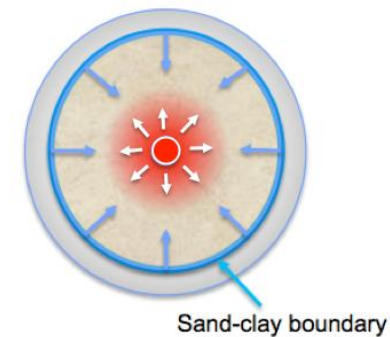

Laboratory Tests and Modeling (5)

High Temperature Column Experiment on Bentonite: Sample Characterizations After Dismantling

Heated column

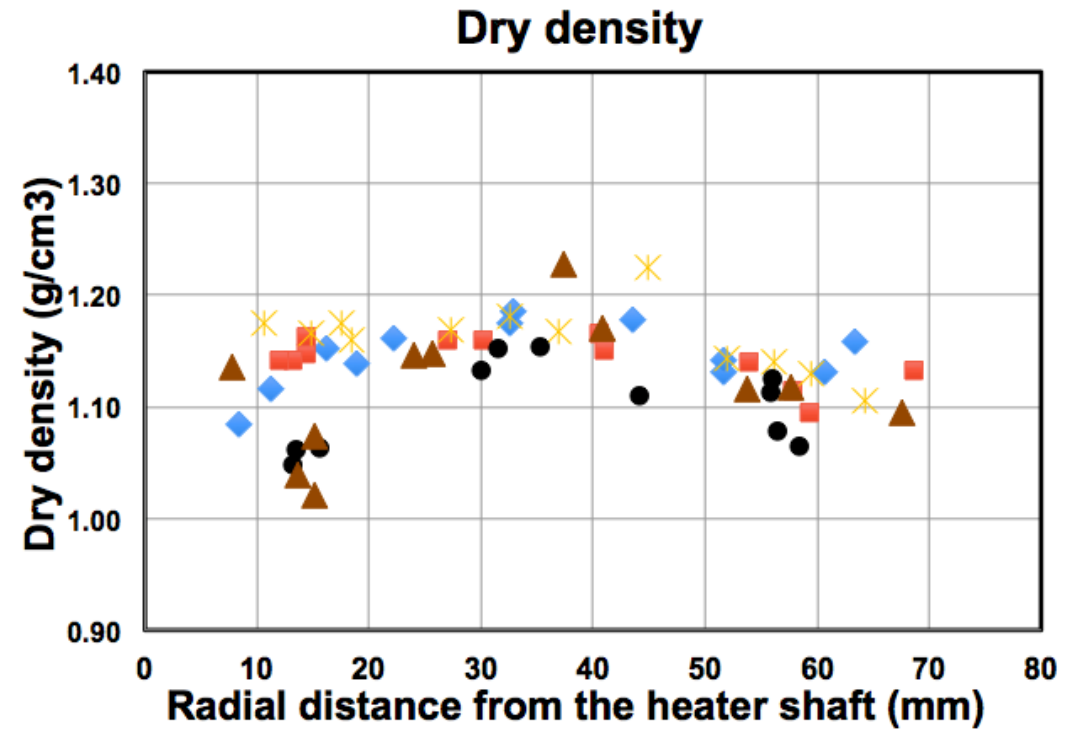
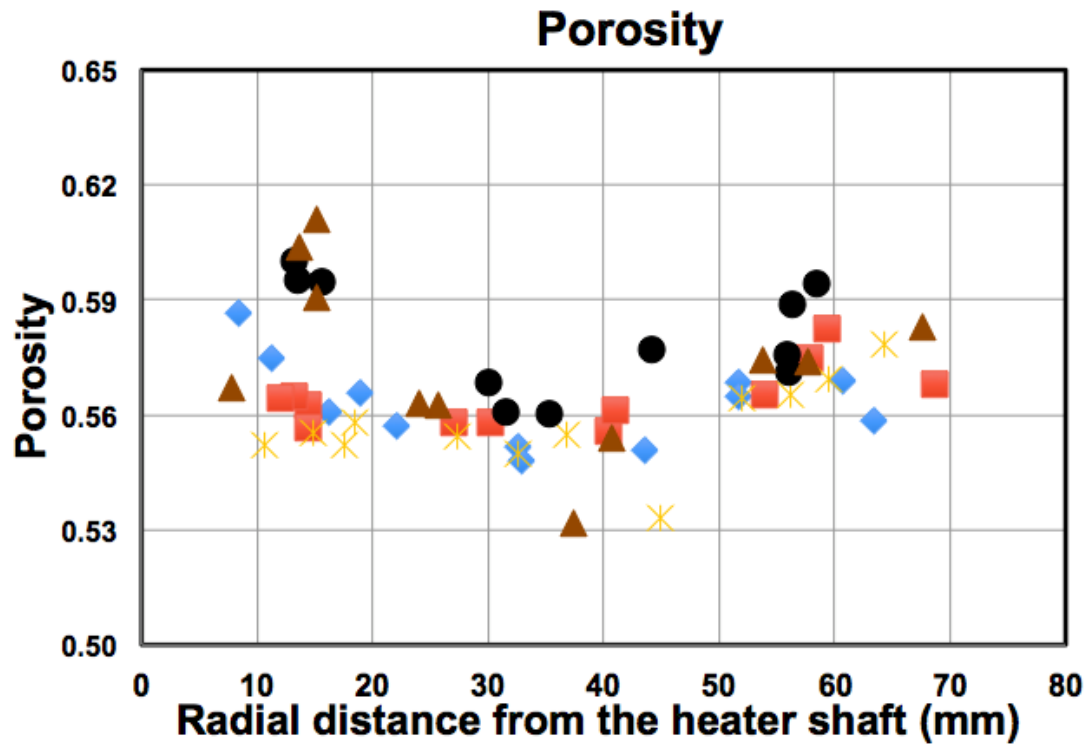

Laboratory Tests and Modeling (6)

High Temperature Column Experiment on Bentonite: Sample Characterizations After Dismantling

- XRD determined precipitate to be 100% anhydrite (CaSO_4)
- SEM is planned to look at structure

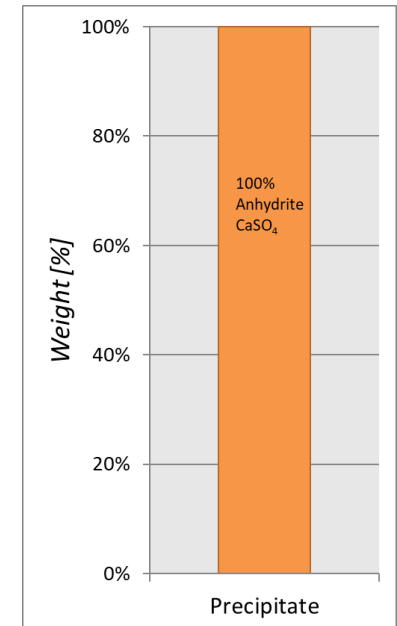
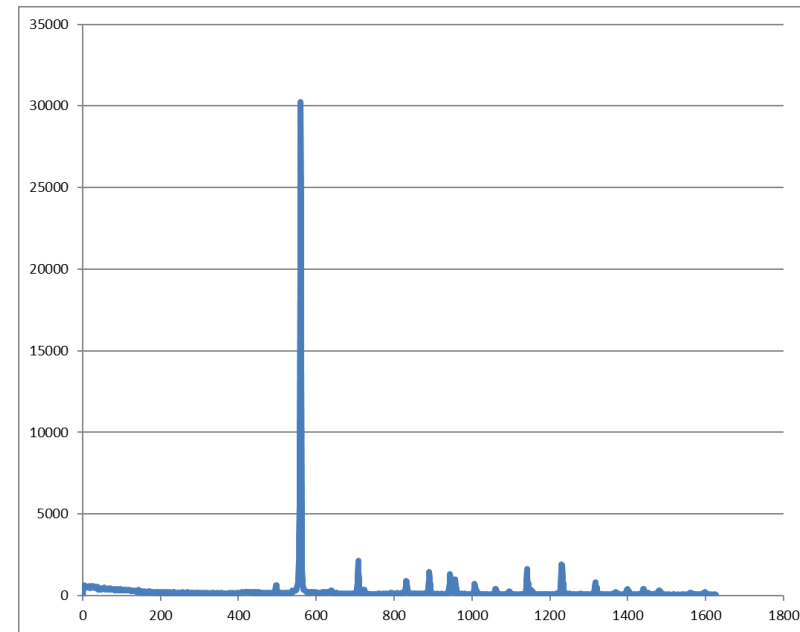
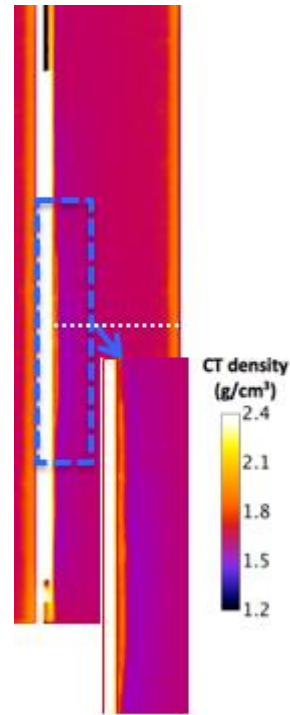

Laboratory Tests and Modeling (7)

Develop THM Model

- For swelling effect, Linear swelling mode and State surface approach
- Initial condition for bentonite and sand layer:
 - Pressure: 0.1MPa
 - Temperature: 20 °C
- Time-dependent temperature boundary at the heater
- Constant pressure boundary at 0.8 MPa (=120 psi)

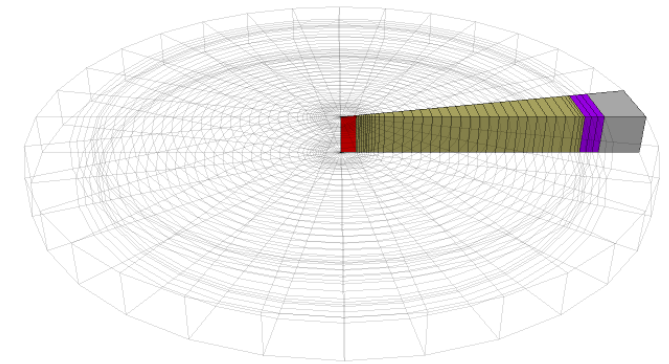
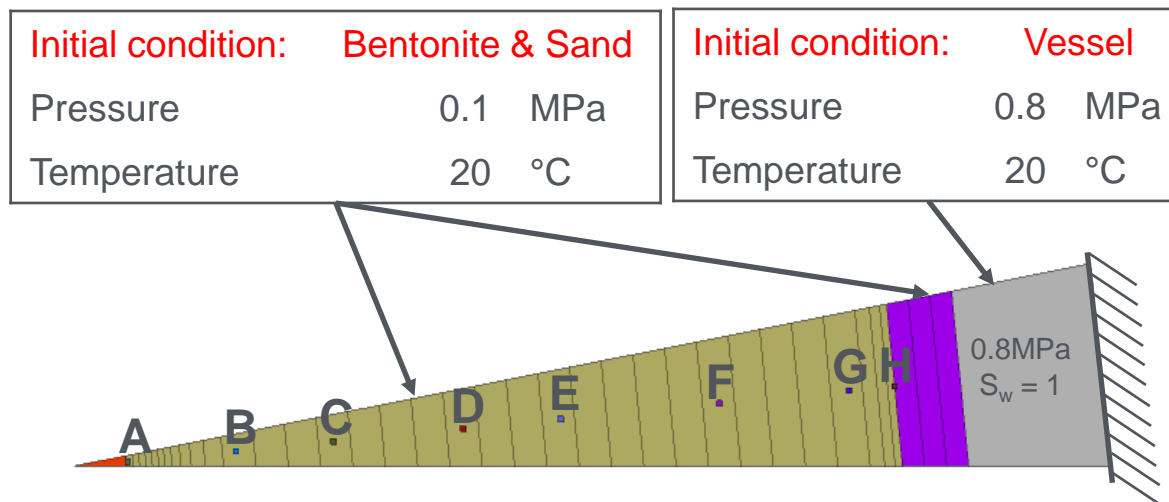

Flow – 1D

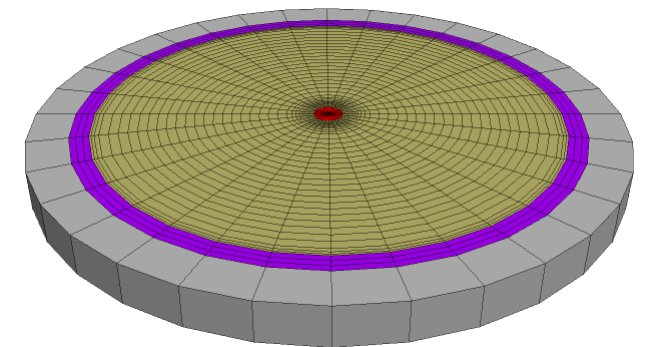

Geomechanics – 2D

Laboratory Tests and Modeling (8)

Model vs Data

Heated column

0 day

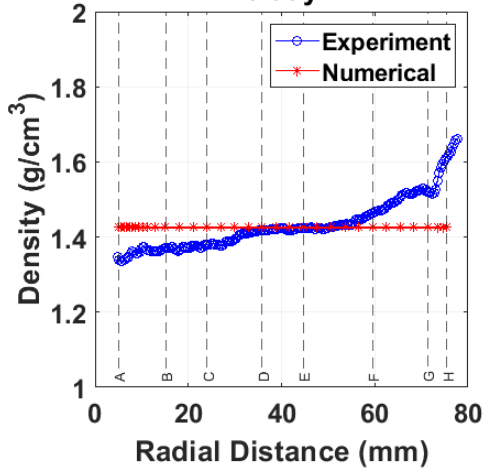

1 day

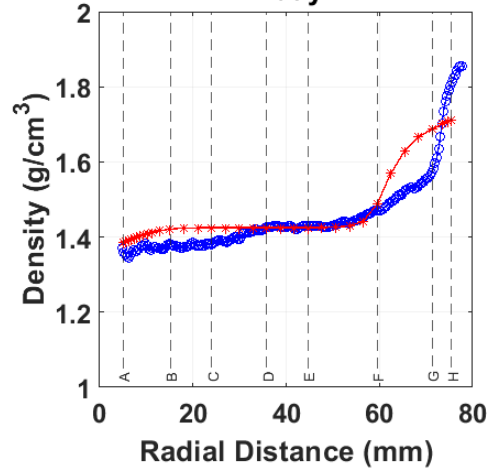

4 day

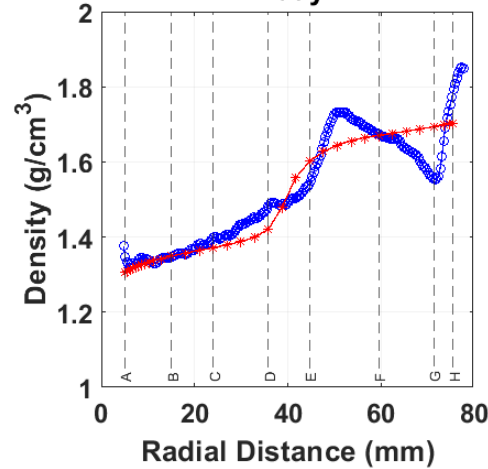

8 day

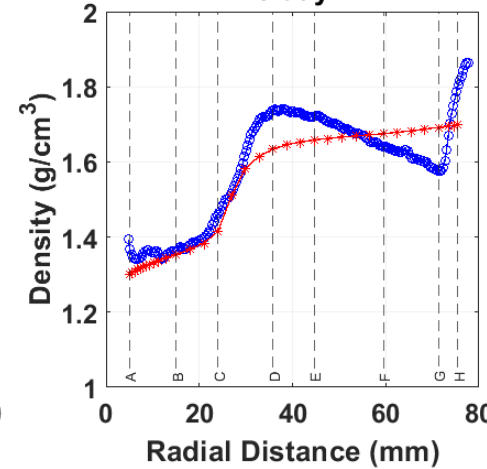

11 day

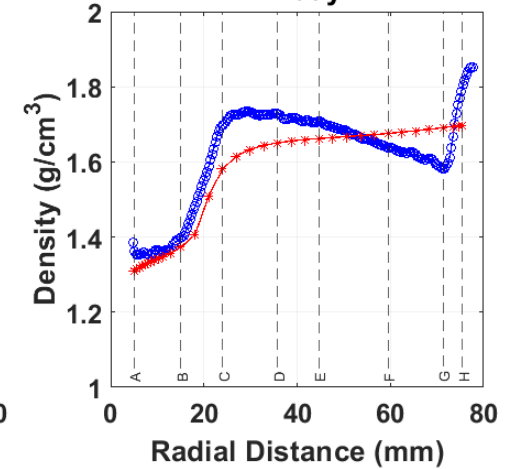

18 day

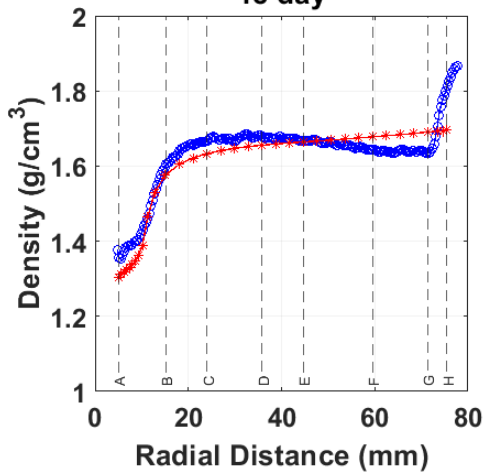

29 day

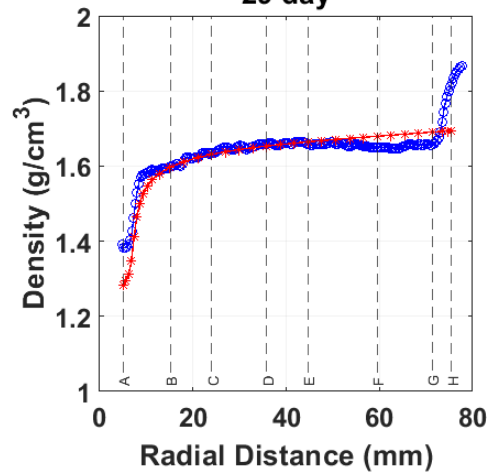

89 day

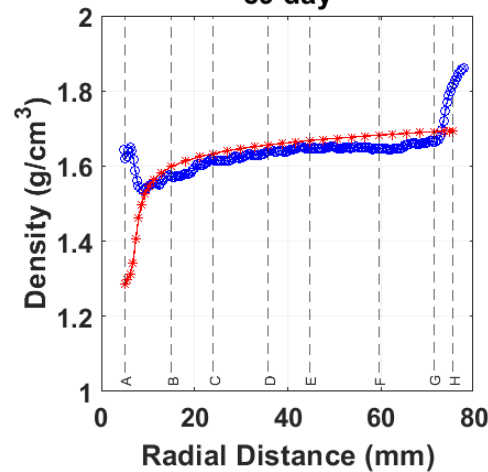

124 day

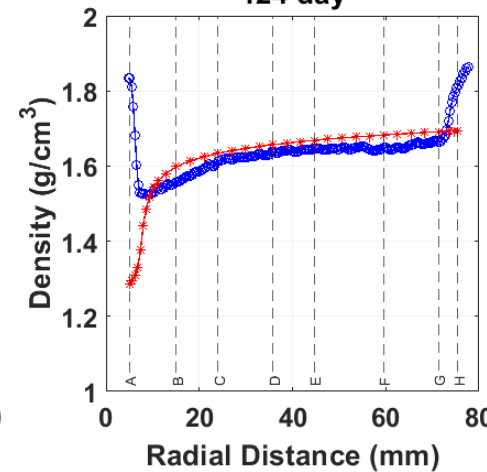

221 day

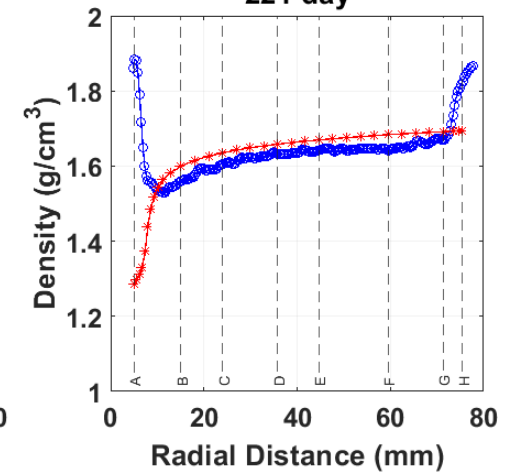

Laboratory Tests and Modeling (9)

Test Key Constitutive Relationship

Heated column

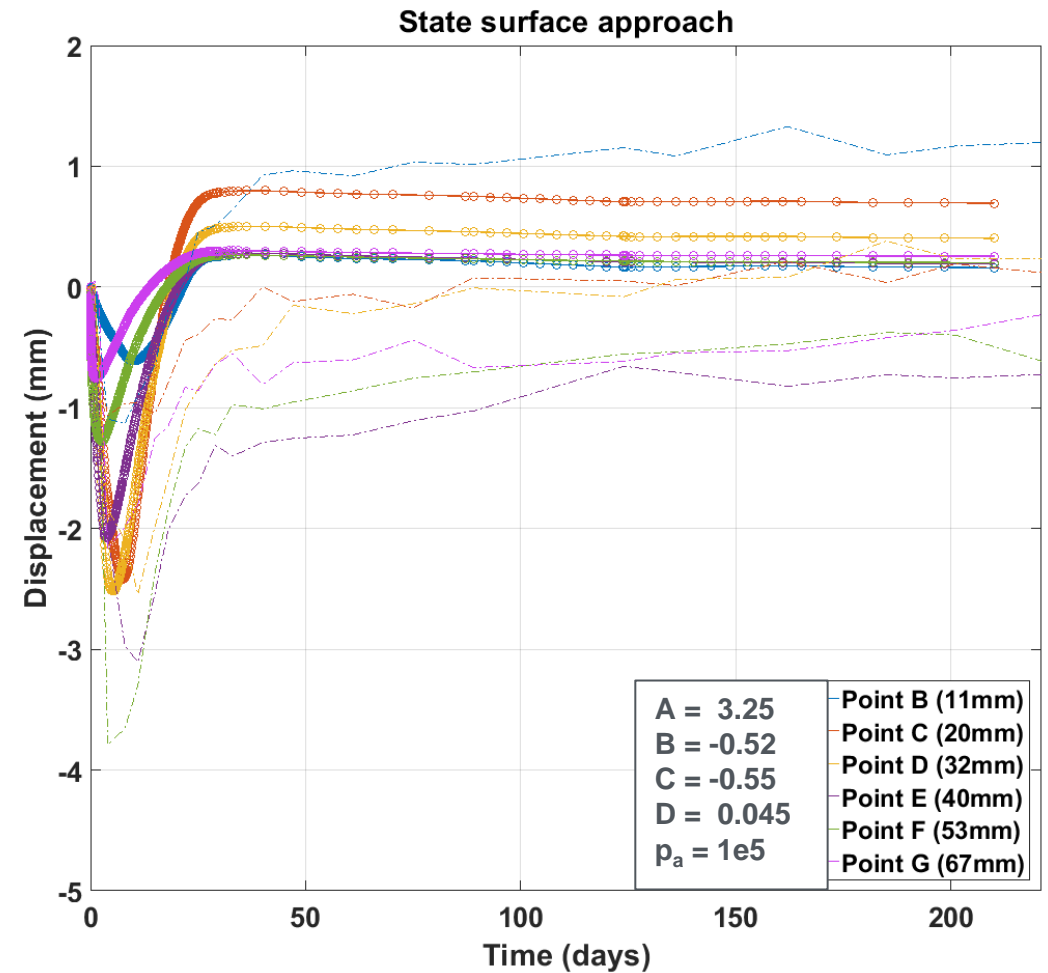
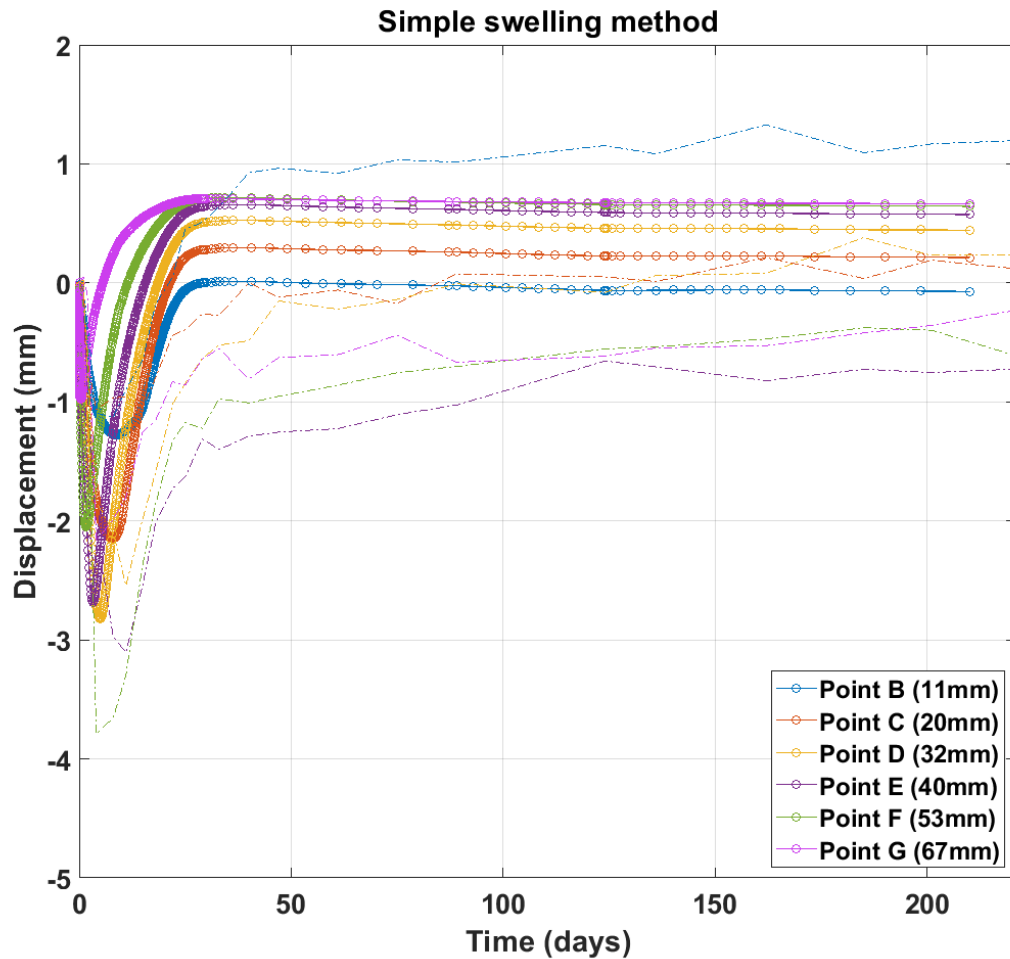

Laboratory Tests and Modeling (10)

Ongoing Work

- Simulating the dynamic THM process is challenging
- Further refine of the mechanical model
- Temperature-dependent water retention curve
- Expansion to THMC model will be conducted after THM model is settled

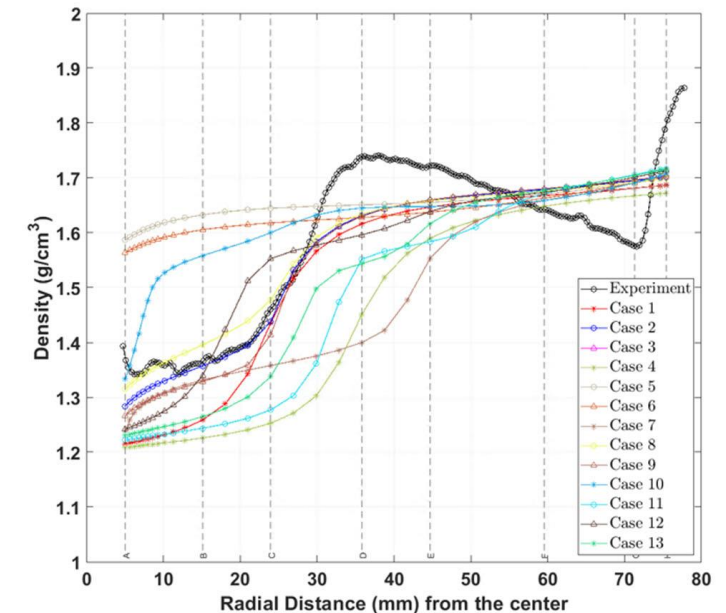
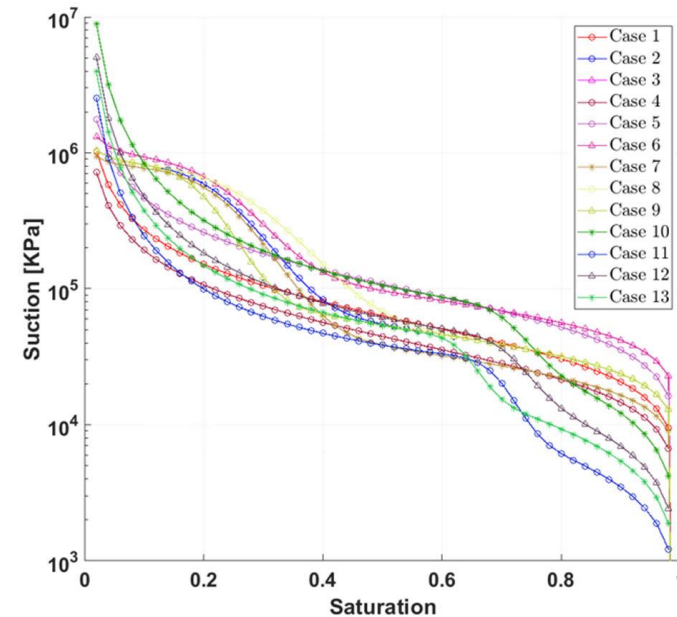
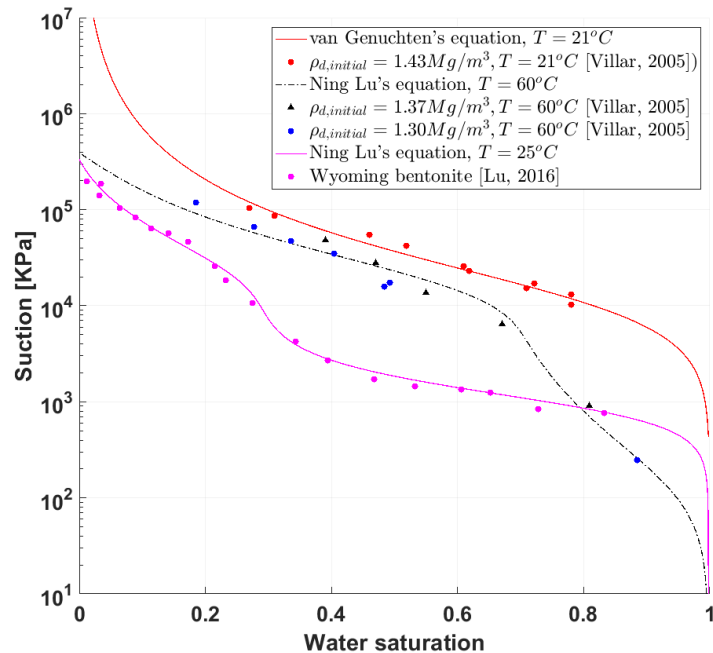

HotBENT Field Experiment (1)

Location



Grimsel area (view to the west)



1 Grimsel Test Site 2 Lake Raeterichboden 3 Lake Grimsel 4 Juchlistock

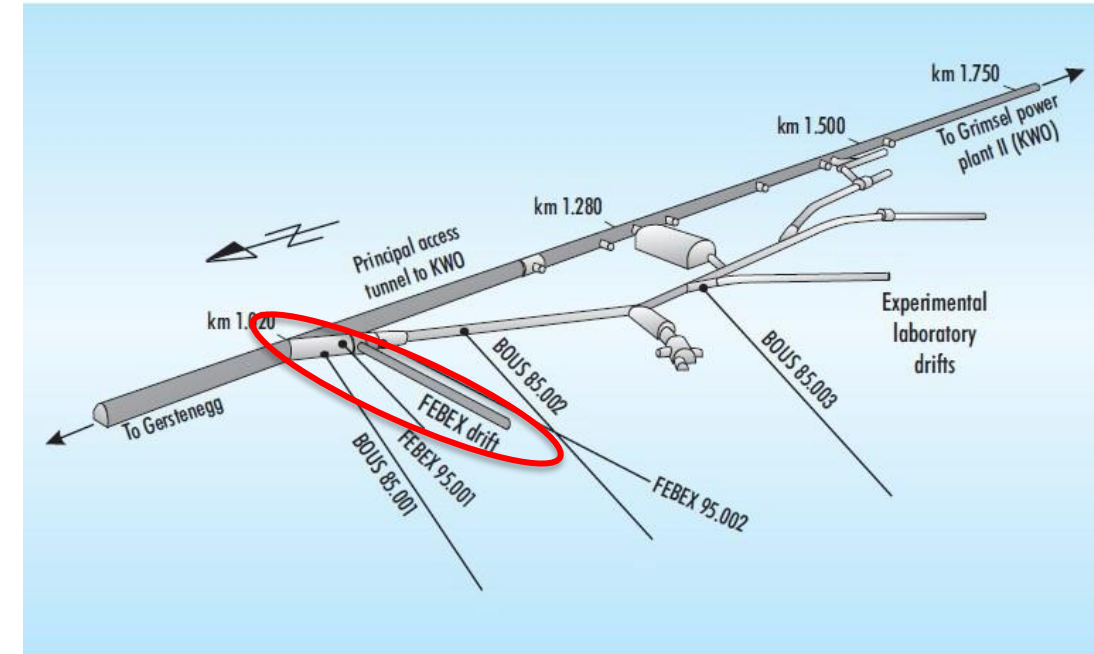

Participating organizations

NAGRA (Switzerland), **DOE**(USA), **NUMO** (Japan), **RWM** (UK), **SÚRAO** (Czech Republic), **NWMO** (Canada), **BGR** (Germany); **ENRESA** (Spain), **Obayashi** (Japan)

HotBENT Field Experiment (2)

Design

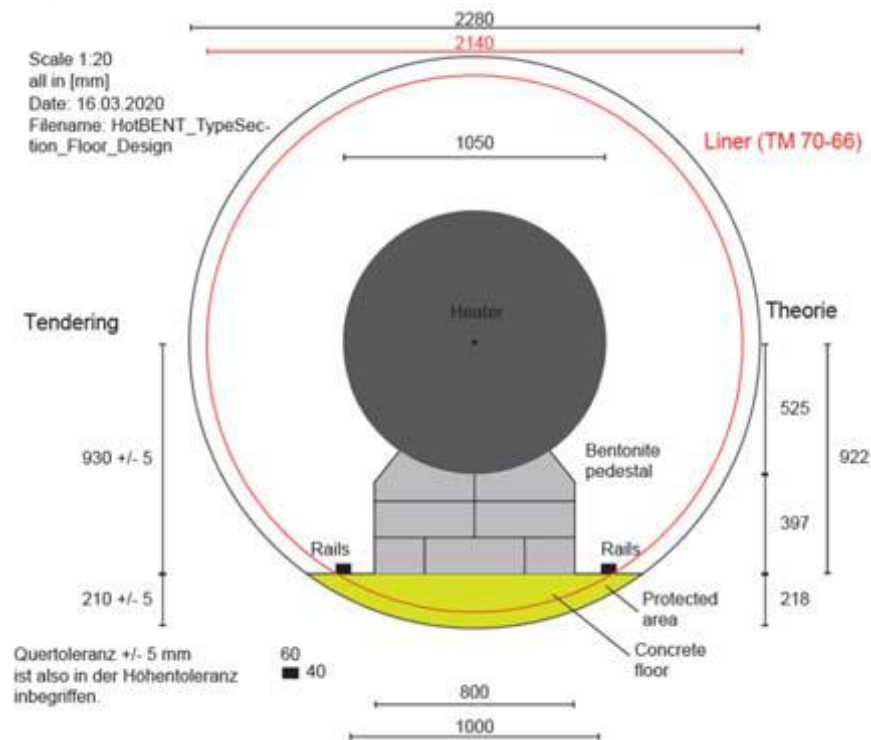
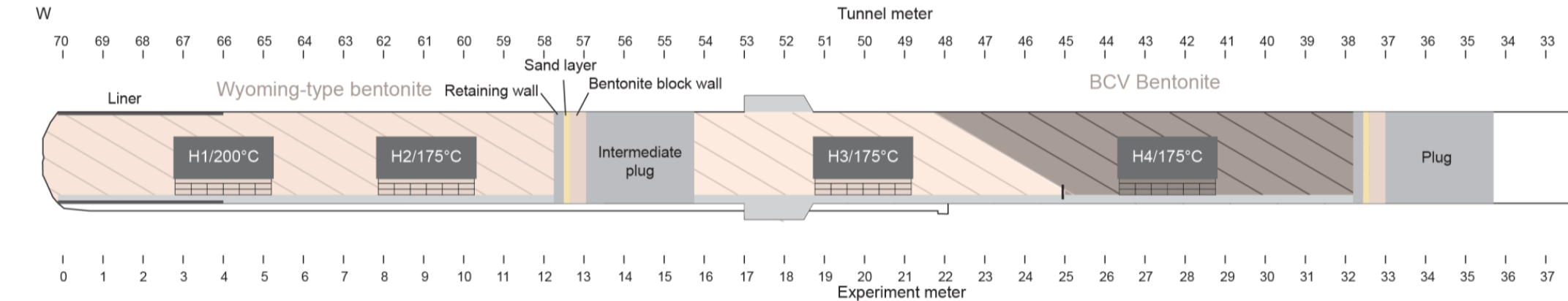

➤ Four modules

- ✓ Differing in heating temperature, bentonite, time length and w/o concrete liner

➤ Two experimental time lengths

- ✓ H3 and H4 will run for 5-10 years
- ✓ H1 and H2 will run 15-20 years

➤ Two bentonites

- ✓ Wyoming (MX-80)
- ✓ BCV (Czech Republic bentonite)

➤ Two shapes

- ✓ Pedestals for the heaters made of highly compacted blocks, dry density > 1.7 g/cm³
- ✓ Granulated Bentonite Mixture (GBM), dry density > 1.45 g/cm³

(Kober, 2020)

HotBENT Field Experiment (3)

Timeline

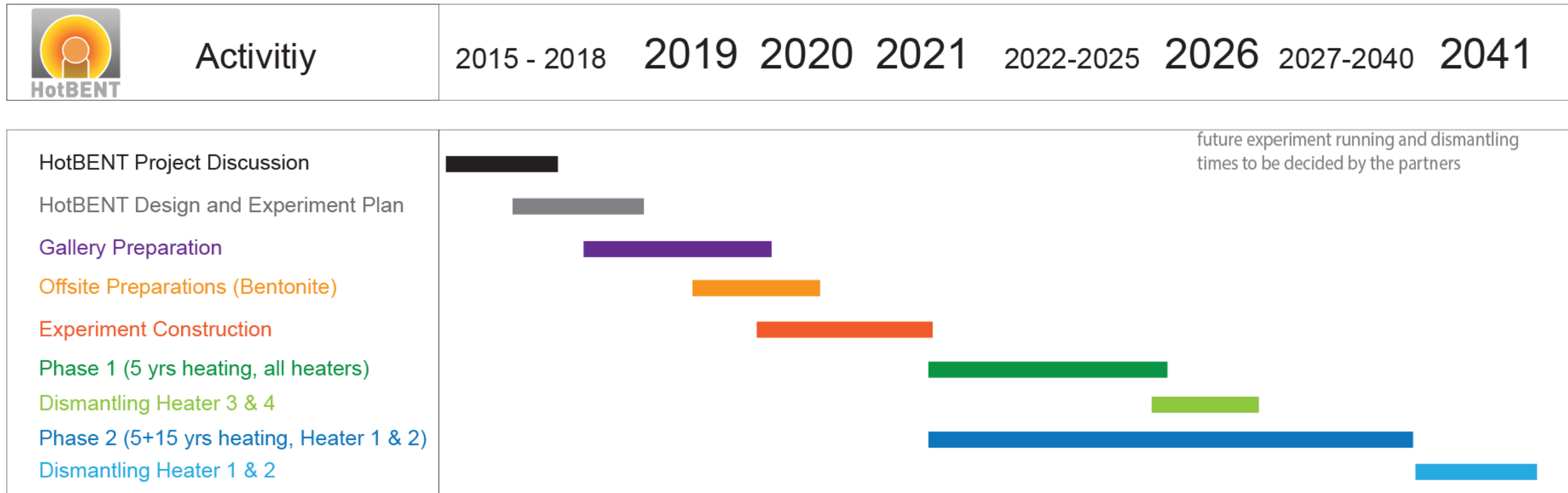

HotBENT Field Experiment (4)

Installation



HotBENT Field Experiment (5)

Instrumentation

Lot 1

Section E'

Measurements of:

- Temperature (T)
- Pore pressure (PP)
- Relative humidity (RH)

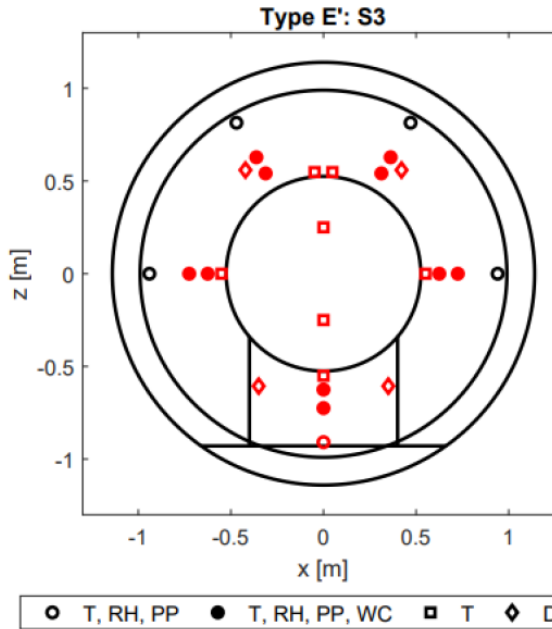

Lot 6

Section E'

Measurements of:

- Temperature (T)
- Pore pressure (PP)
- Relative humidity (RH)
- Total pressure (TP)
- Water content (WC)
- Displacement (D)

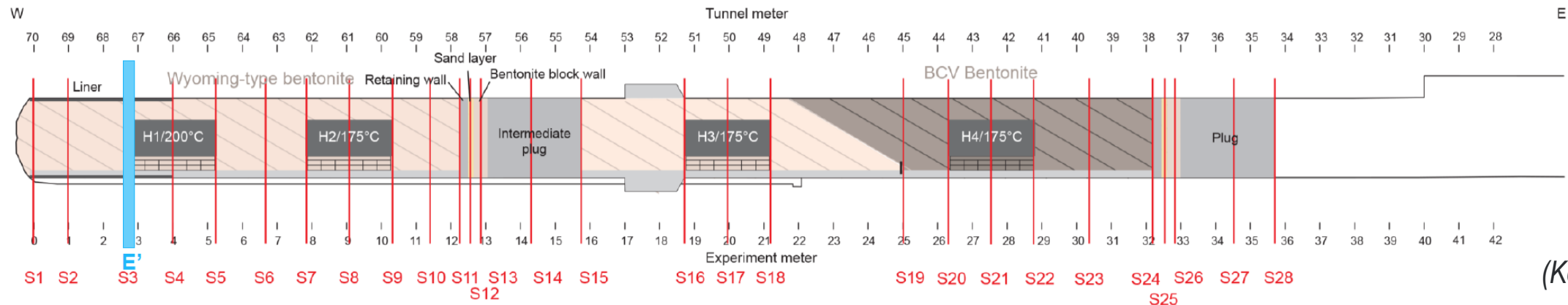

(Kober, 2020)

HotBENT Field Experiment (6)

HotBENT Emplacement -Milestones

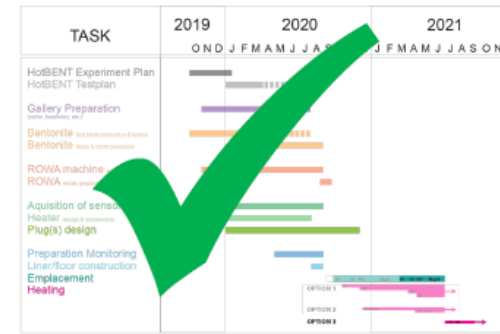
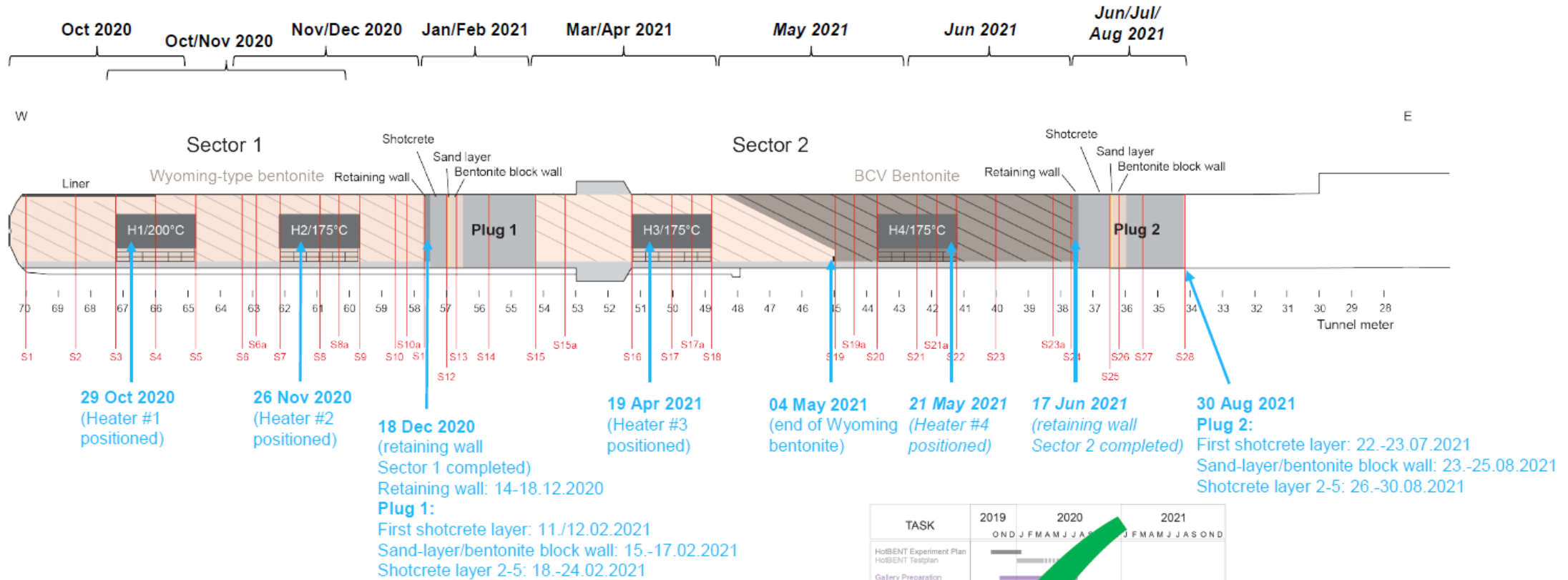

Data: 28 Apr 2021 - assuming no major delays caused by the ongoing effects and measures of the Covid-19 virus

HotBENT Field Experiment (7)

- Heating Started on Sep 9, 2021
- Heaters have been ramped up in steps.
- By June 2, all heaters reached their targeted temperature

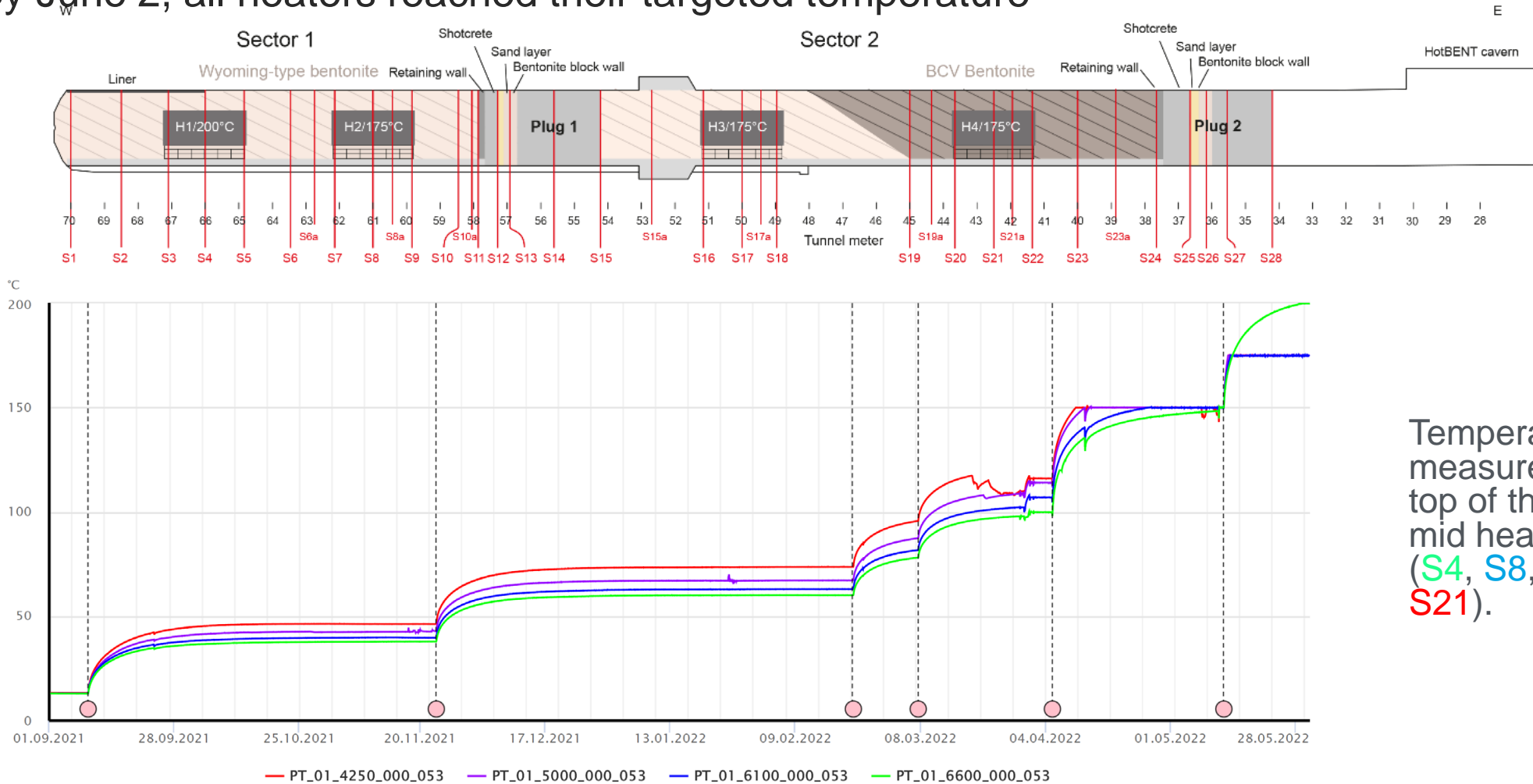

Temperature measurements on top of the heater at mid heater sections (S4, S8, S17 and S21).

HotBENT Modeling (1)

HotBENT Modeling Platform was established

- Overarching goal:
 - Assess with “initial” modelling the capability of various approaches based on existing laboratory data and simplified assumptions to capture the behavior of the system
 - Interpret the observed behavior based on limited calibration (data release cycles) and predict (including uncertainty) the evolution of the system
 - Predict the state and inform in advance of the partial (and at a later stage full) dismantling activities.

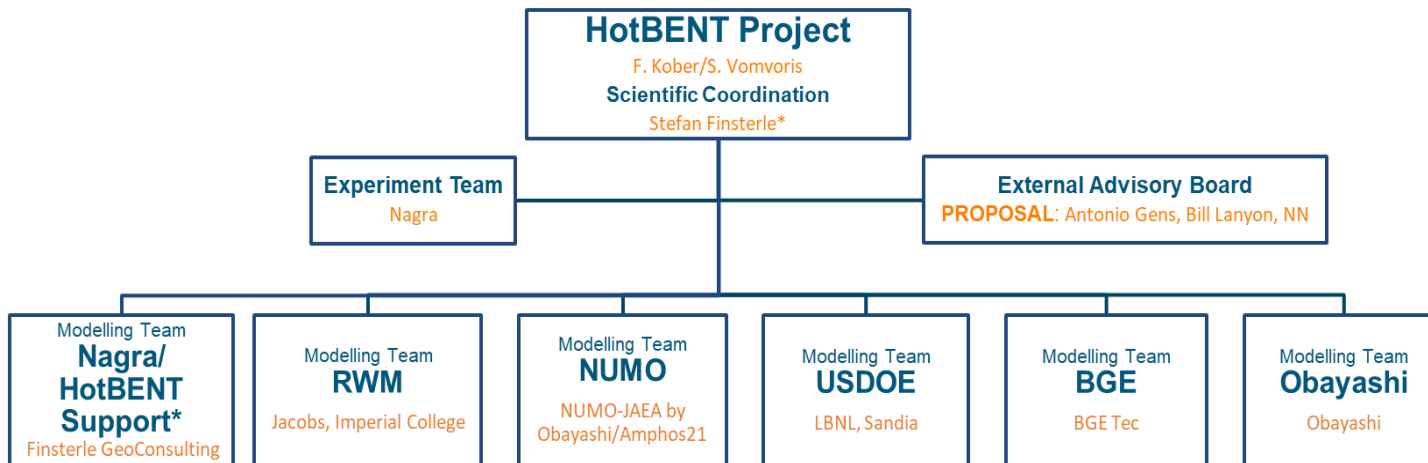

SNL Modeling: THMC process at interfacial areas, e.g. metal corrosion at metal-buffer material interfaces

*following the discussion of the 2nd HMP Meeting (18/19 Jan 2022) **Design and Operational Model Support, Nagra interest (UQ, etc.)

HotBENT Modeling (2)

Coupled THMC model

Goal: Increase the predictability of THMC evolution of bentonite under high temperature: focusing on Improved constitutive relationships under high T, long term geochemical evolution and UQ.

Ongoing:

- 3-D TH model

Next steps:

- Expanding the 3-D TH model to THM model
- Make blind prediction of the 1-year response in the field test
- Refinement the model based on the goodness-of-fit of 1-year data
- Make long term prediction using the refined model
- Expanding the THM model to THMC model
- UQ for THMC model

Code: TOUGHREACT-FLAC3D, sequentially coupled THMC code

Performance measure: use as much data as possible in bentonite and geosphere

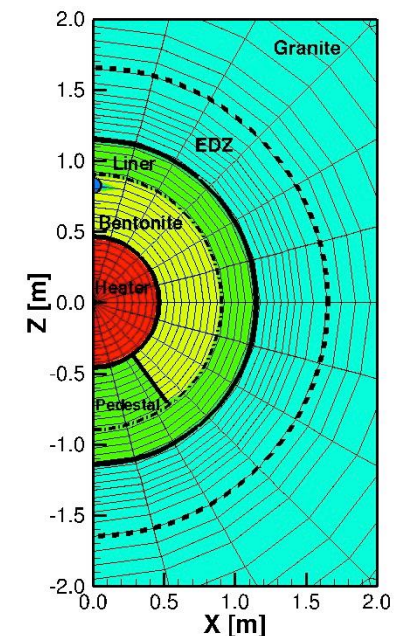
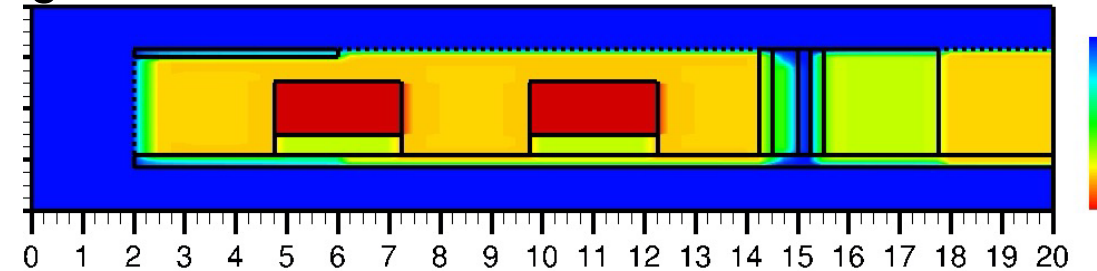

Integration coupled THMC models with Generic Disposal

- Developing advanced modeling tools
- Constructing multi-physics coupled process models
- Testing models with large scale experiments



- Supplying generic Performance Assessment (PA) models with reliable conceptual model and parameters
- Providing generic PA models with well-tested constitutive relationships
- Integrating process models into PA

Field Experiments



Generic PA Modeling

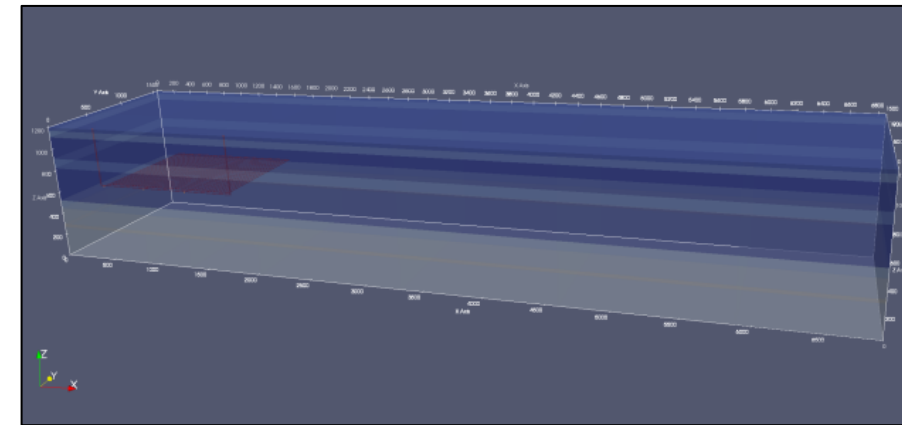

Summary

- Understanding and modeling of THMC perturbations in bentonite buffer is critical for clay repository
- Experience was gained for THMC process under low temperature, but recent studies have been dedicated to high temperature conditions.
- Generic models, laboratory field experiments and the corresponding modeling work have been conducted.
- Understanding of the alteration of bentonite buffer is enhanced and modeling capability is improved, which will be integrated into Generic Disposal Systems Analyses (GDSA) for performance assessment.

References

- ERESA, 2000. Full-scale engineered barriers experiment for a deep geological repository in crystalline host rock FEBEX Project. EUR 19147 EN, European Commission.
- Kober F., Villar M.V., Turrero M., Wersin P., Gaus I & FEBEX-DP Consortia, 2017. FEBEX-DP: Dismantling FEBEX after 18 years – activities, results, conclusions. Clay Conference 2017, Davos, 25.09.2017.
- Leupin O.X. (ed.), Birgersson M., Karnland O., Korkeakoski P., Sellin P., Mäder U., Wersin P., 2014. Montmorillonite stability under near-field conditions. Nagra Technical Report NTB 14-12.
- Wersin P. and Kober F., 2017. FEBEX-DP Metal Corrosion and Iron-Bentonite Interaction Studies, NAB 16-16
- Zheng L., Rutqvist, J. Birkholzer J. T. and Liu, H.H., 2015. On the impact of temperatures up to 200 °C in clay repositories with bentonite engineer barrier systems: A study with coupled thermal, hydrological, chemical, and mechanical modeling. Engineering Geology 197: 278-295.
- Zheng L., Rutqvist J., Xu H. and Birkholzer J. T., 2017. Coupled THMC models for bentonite in an argillite repository for nuclear waste: Illitization and its effect on swelling stress under high temperature. Engineering Geology 230: 118-129.
- Zheng, L., Xu, H., Rutqvist, J., Reagan, M., Birkholzer, J., Villar, M. V., and Fernández, A. M. (2020b). The hydration of bentonite buffer material revealed by modeling analysis of a long-term in situ test. Applied Clay Science, 185:105360.